

NORA[®]
LIGHTING



BACKLIT PANELS
RECESSED, SURFACE OR SUSPENDED





PANELS

LED BACKLIT

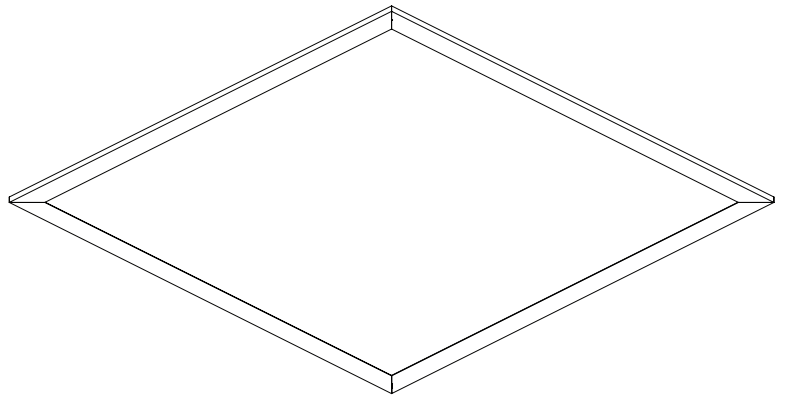

LED Panels effectively deliver ambient upper light while also projecting foot candles to the work surface. These energy efficient luminaires are an excellent choice for offices, retail stores, conference rooms, libraries, hospitals and other indoor applications where long life and uniform illumination is required. Panels are available with a selectable CCT switch or dedicated 5000K units. Selectable lumen panels are versatile at offering six different options in one unit.

BACKLIT PANELS COMMERCIAL AND ARCHITECTURAL

SELECTABLE CCT or DEDICATED 5000K

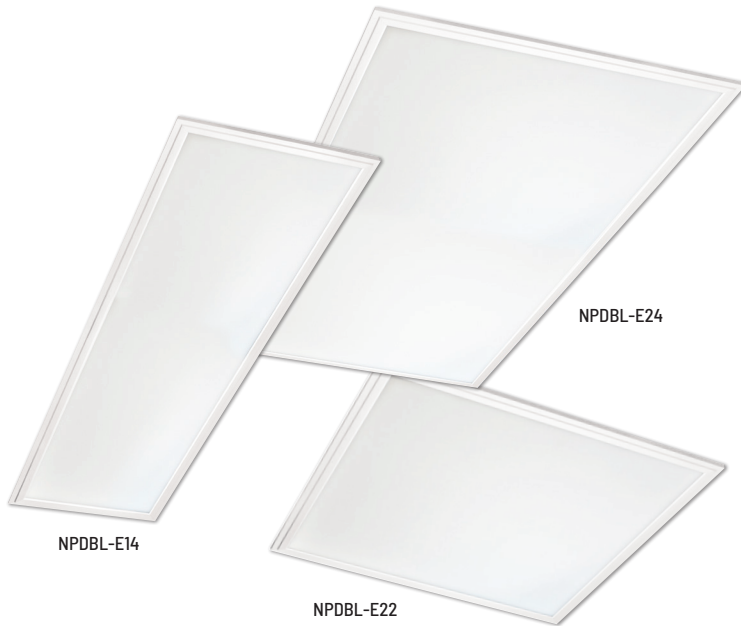

BACKLIT PANELS

SIZE / LUMENS / WATTAGE	COLOR TEMPERATURE	FINISH	EMERGENCY
NPDBL-E14 1' x 4' / 3500lm / 30W NPDBL-E22 2' x 2' / 3500lm / 30W NPDBL-E24 2' x 4' / 5600lm / 45W	/334 Selectable CCT (3000K/3500K/4000K)	W White	EM Emergency with Remote Test Switch MS Motion Sensor
NPDBL-E22 2' x 2' / 3500lm / 30W NPDBL-E24 2' x 4' / 5700lm / 45W	/50 Dedicated 5000K	W White	EM Emergency with Remote Test Switch

Example: **NPDBL-E22/334W** - 2' x 2' LED Backlit Panel, 3500lm / 30W, Selectable CCT (3000K / 3500K / 4000K), White Finish

DESIGN PERFORMANCE FEATURES:

- 2' x 2', 1' x 4' and 2' x 4' configurations
- Field selectable CCT (3000K / 3500K / 4000K) or dedicated 5000K
- Diffused white opalescent lens optimizes output while reducing diode image
- Sealed optics require no maintenance
- Replaces 2' x 2', 1' x 4' or 2' x 4' ceiling panels for easy installation
- White frame
- Mounting kits available for pendant, surface or recessed hard ceiling
- Dimmable down to 5% with compatible 0-10V dimmer
- Optional emergency battery backup and motion sensor
- L70 at 60,000 hours
- 5-Year limited warranty
- cULus Listed for Damp Location
- DLC Listed

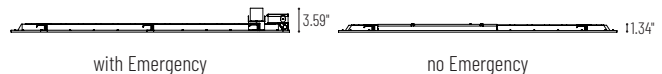
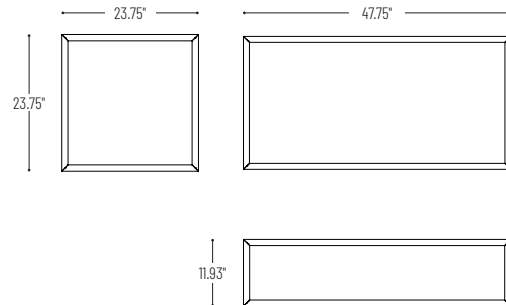

COMMERCIAL AND ARCHITECTURAL BACKLIT PANELS

SELECTABLE LUMENS & CCT

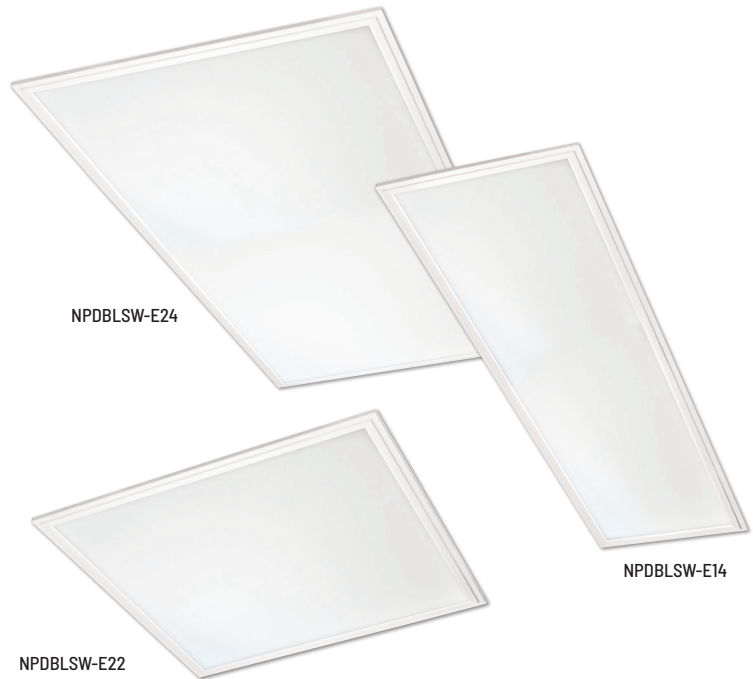
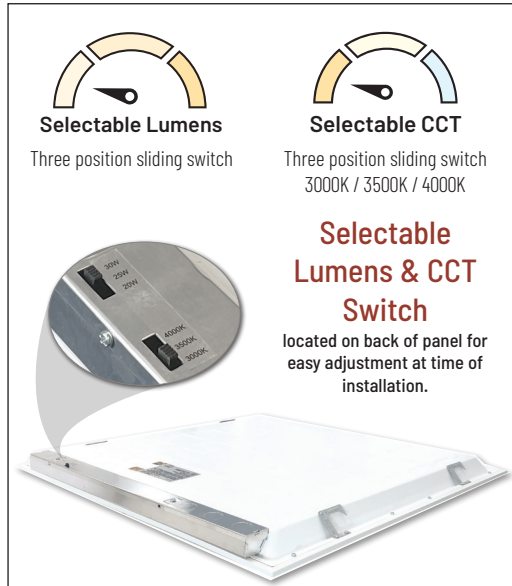

BACKLIT PANELS WITH SELECTABLE LUMENS & CCT

LUMENS / WATTAGE	COLOR TEMPERATURE	FINISH	EMERGENCY
NPDBLSW-E14 1' x 4' / 2600lm-3650lm / 20W-30W	/334 Selectable CCT (3000K/3500K/4000K)	W White	EM Emergency with Remote Test Switch
NPDBLSW-E22 2' x 2' / 2650lm-3750lm / 20W-30W			
NPDBLSW-E24 2' x 4' / 4600lm-5700lm / 36W-45W			

Example: NPDBLSW-E22/334W - 2' x 2' LED Backlit Panel, 2650lm-3750lm / 20W-30W, Selectable CCT (3000K / 3500K / 4000K), White Finish

DESIGN PERFORMANCE FEATURES:

- 2' x 2', 1' x 4' and 2' x 4' configurations
- Field selectable Lumens & Wattage
- Field selectable CCT (3000K / 3500K / 4000K)
- Diffused white opalescent lens optimizes output while reducing diode image
- Sealed optics require no maintenance
- Replaces 2' x 2', 1' x 4' or 2' x 4' ceiling panels for easy installation
- White frame
- Mounting kits available for pendant, surface or recessed hard ceiling
- Dimmable down to 5% with compatible 0-10V dimmer
- L70 at 60,000 hours
- 5-Year limited warranty
- cULus Listed for Damp Location
- DLC Listed

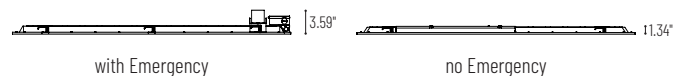
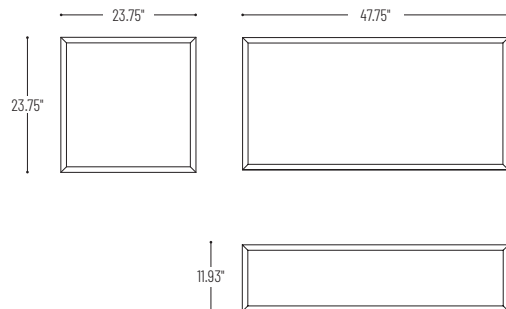

PANEL ACCESSORIES



Surface Mounting Frame for LED Panels

NPDBL-14DFK/W 1' x 4' without Emergency

NPDBL-14DDFK/W 1' x 4' with Emergency

NPDBL-22DFK/W 2' x 2' without Emergency

NPDBL-22DDFK/W 2' x 2' with Emergency

NPDBL-24DFK/W 2' x 4' without Emergency

NPDBL-24DDFK/W 2' x 4' with Emergency

Clean sharp edges in a natural aluminum or white finish. Frame mounts over an existing junction box and panel slides into place. Surface frame extends only 2.5" or 4.33" from the ceiling. May be used with NPDBL-PKW pendant kit.



Recessed Mounting Kit for LED Panels

NPDBL-14RFK/W 1' x 4'

NPDBL-22RFK/W 2' x 2'

NPDBL-24RFK/W 2' x 4'

The white finished flange kit consist of four pieces. The assembled frame installs into a hard ceiling. The LED panel lifts and shifts in the frame ending in a finished flush appearance.



Universal Pendant Mounting Kit for LED Panels

NPDBL-PKW

Allows LED panel to be suspended as a pendant. White aluminum finished canopy has four hanging points for 2x2 unit and six for 1x4 and 2x4 units. Grip lock fasteners allow field adjustment of cables from 12" to 96". Canopy includes an 8' power cord that can be shortened in the field. Pendant kit may be used with surface frame for an alternate appearance.



4 Junction Box for Daisy Chaining

NPDBL-JB4X4

Junction box mounts on panel to allow them be daisy chained together on the same switch. (4-in / 4-out)





NORA LIGHTING, INC.
6505 Gayhart St.
Commerce, CA 90040
TEL 323.767.2600
FAX 323.722.3677
www.NoraLighting.com

DOMESTIC FACILITIES:

Atlanta, GA
Cincinnati, OH
Dallas, TX
Detroit, MI
Edison, NJ
Los Angeles, CA
Louisville, KY
Minneapolis, MN
Nashville, TN

INTERNATIONAL SALES:

6505 Gayhart St.
Commerce, CA 90040
TEL 323.767.2600
FAX 323.722.3677

The products shown in this catalog
are covered by USA and International
patents. Specifications subject to
change without notice.

© Copyright 2023 Nora Lighting, Inc.
All rights reserved

