

# Installation Instructions

## NATL-SWEX60/12A

### 12V NEXUS Dimmer & Driver

READ PRIOR TO ATTEMPTING INSTALLATION  
ALWAYS TURN OFF MAIN POWER BEFORE INSTALLATION  
INSTALLATION SHOULD BE CARRIED OUT BY YOUR LOCAL ELECTRICIAN

**⚠ WARNING** - This equipment is intended to be installed only by qualified personnel. The installation must be made in accordance with the current edition to the National Electric Code and all applicable state and local building codes. The final installation must be approved by the appropriate qualified electrical/building inspector(s). Improper installation may result in a fire or electrical hazard. Be sure the electrical power to the circuit has been disconnected before installing this electrical system.

**⚠ AVERTISSEMENT** - Cet équipement est destiné à être installé uniquement par du personnel qualifié. L'installation doit être faite en conformité avec l'édition actuelle du Code national de l'électricité et toutes étatiques et locales codes du bâtiment applicables. L'installation finale doit être approuvée par l'inspecteur en électricité / bâtiment qualifié approprié(s). Une mauvaise installation peut entraîner un incendie ou un risque électrique. Soyez sûr de la puissance électrique vers le circuit a été coupée avant l'installation de ce système électrique.

#### SAFETY & WARNING:

- Unlike traditional dimming controls, NEXUS requires unique wiring steps. Read all warnings and installation instructions thoroughly.
- NEC Code 725.136: Class 1 and Class 2 circuits in same enclosure must be separated by a barrier unless Class 2 circuit conductors are installed in accordance with 725.41 Class 1 Circuits.
- Only install compatible 12V Constant Voltage DC fixtures or warranty will be void.
- Do not modify product beyond instructions or warranty will be void.
- Contrairement à des contrôles de gradation traditionnels, NEXUS nécessite des étapes uniques de câblage. Lire tous les avertissements et les instructions d'installation à fond.
- NEC code 725.136 : classe 1 et classe 2 circuits dans la même enceinte doivent être séparés par une barrière à moins conducteurs de classe 2 de circuit sont installés conformément à 725,41 classe 1 Circuits.
- Installez uniquement une tension constante appareils DC compatibles 12V ou garantie sera annulée.
- Ne pas modifier le produit au-delà des instructions ou garantie sera annulée.



#### PACKAGING CONTENTS

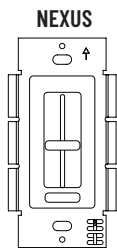

NEXUS

Barrier

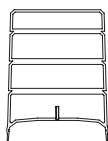

Glossy White Face Plate

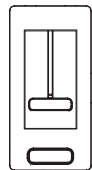

Twisted Wire Connector (4)



Mounting Screw (2)



#### APPROVED LED FIXTURES

NEXUS is compatible with 12V system by Nora Lighting and others including but not limited to:

- Standard Tape Light



#### TOOLS NEEDED

Flat-head Screwdriver



Phillips-head Screwdriver



Pliers

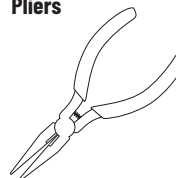

#### INSTALLATION INSTRUCTIONS

##### 1. TURN POWER OFF AT CIRCUIT BREAKER.



**SHOCK HAZARD! MAY RESULT IN SERIOUS INJURY OR DEATH. TURN POWER OFF AT CIRCUIT BREAKER PRIOR TO INSTALLATION.**

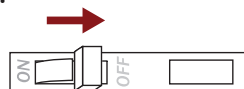

##### 2. DETERMINE LOCATION TO INSTALL COMPONENTS.

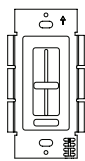

NEXUS

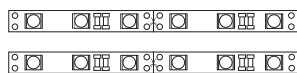

Low Voltage Tape Light / Fixture

**⚠ IMPORTANT:** Verify the voltage of the Nora product matches the Nora NEXUS output. NEXUS LED driver is a 12V DC unit.

##### 3. REMOVE EXISTING SWITCH (IF NECESSARY)

- Remove trim plate and switch mounting screws.
- Pull switch from wall.
- Identify wires connected to switch and mark wires if desired.
- Disconnect wires from switch.

##### 4. CHOOSE FACE PLATE FINISH (IF NECESSARY)

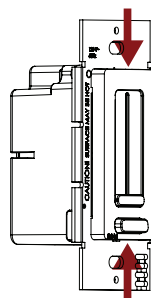

a. Gently squeeze top and bottom of face plate

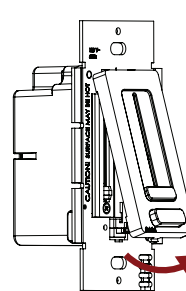

b. Lift face plate from housing

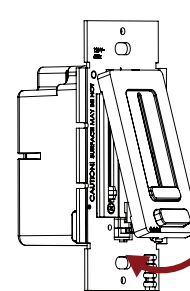

c. Insert replacement face plate into top housing groove. Position housing slider and face plate slider at minimum brightness (bottom level) and pop on face plate

# Installation Instructions

NATL-SWEX60/12A

12V NEXUS Dimmer & Driver

READ PRIOR TO ATTEMPTING INSTALLATION  
ALWAYS TURN OFF MAIN POWER BEFORE INSTALLATION  
INSTALLATION SHOULD BE CARRIED OUT BY YOUR LOCAL ELECTRICIAN

## INSTALLATION INSTRUCTIONS

### 5. REMOVING FINS (IF NECESSARY)

It's required to break off dimmer fins when ganging multiple dimmers in same wall box

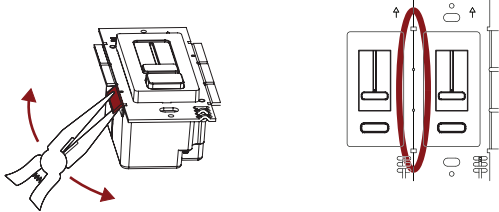

Grip with pliers. Bend back and forth until fin breaks off

Fins have been removed

### ZERO LOAD DERATING

Unlike standard high voltage AC controls, removing NEXUS fins does not reduce the dimmer's maximum wattage rating.

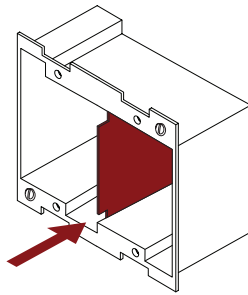

Removeable Partition

Install gang boxes that include vertical partitions (available at local electrical distributor) unless Class 2 circuit conductors are installed in accordance with 725.41 Class 1 Circuits.

### 6. ATTACH VOLTAGE PARTITION (BARRIER)

A voltage barrier is provided, which separates high voltage and low voltage wires in the wall box. Attach before mounting.

#### NEC CODE 725.136

Class 1 and Class 2 circuits in same enclosure must be separated by a barrier unless Class 2 circuit conductors are installed in accordance with 725.41 Class 1 Circuits. For example, Non-Metallic (NM) cable is considered a Class 1 circuit conductor. Therefore, if both high voltage and low voltage circuits are installed with NM cable then the voltage barrier is not required for installation.

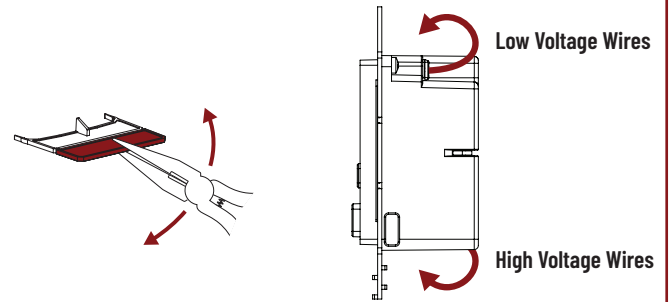
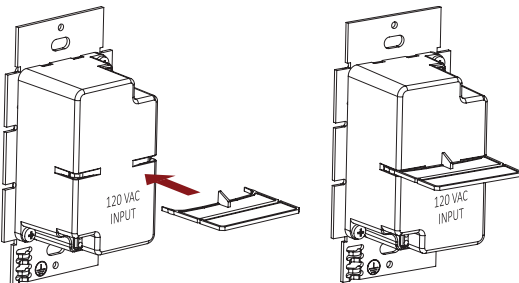

For shallow boxes, barrier can be shortened. Grip with pliers. Bend back and forth until fin breaks off.

For extra shallow wall boxes it's acceptable to use the dimmer housing as a barrier. Tuck wires on top and bottom sides of dimmer housing.

### 7. WIRE DIMMER

a. Strip wires on dimmer

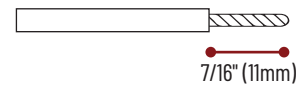

b. Wire dimmer. Ensure main power is OFF

- GND (Green): To ground wire in box.
- V+ (Red): To low voltage V+
- V- (Blue): To low voltage V-
- N (White): To 120V Neutral
- H (Black): To 120V Line Hot

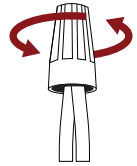

### VOLTAGE DROP

See VOLTAGE DROP CHARTS at the end of this guide for wire gauge recommendations installed between dimmer and fixture.

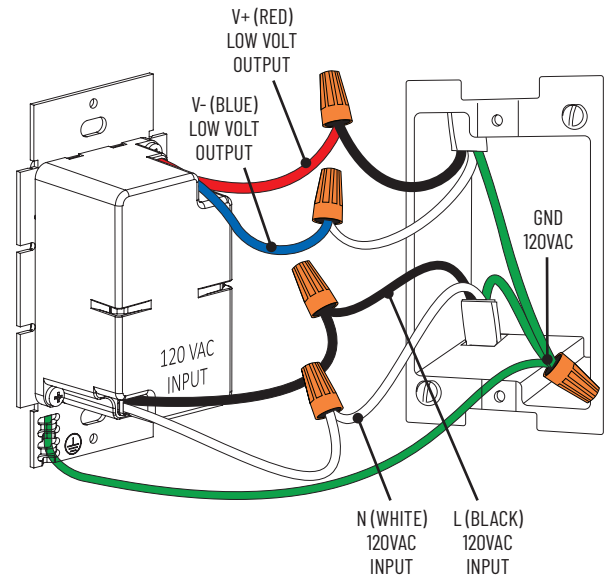

**IMPORTANT:** Verify the voltage of the Nora product matches the Nora NEXUS output. NEXUS LED driver is a 12V DC unit.

# Installation Instructions

NATL-SWEX60/12A

12V NEXUS Dimmer & Driver

**READ PRIOR TO ATTEMPTING INSTALLATION**  
**ALWAYS TURN OFF MAIN POWER BEFORE INSTALLATION**  
**INSTALLATION SHOULD BE CARRIED OUT BY YOUR LOCAL ELECTRICIAN**

## INSTALLATION INSTRUCTIONS

### SYSTEM DIAGRAM:

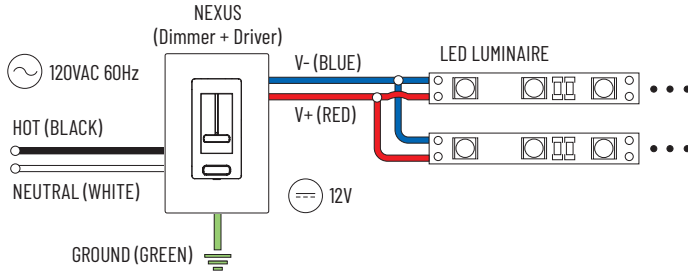

### 8. MOUNT DIMMER TO WALLBOX AND ATTACH TRIM PLATE

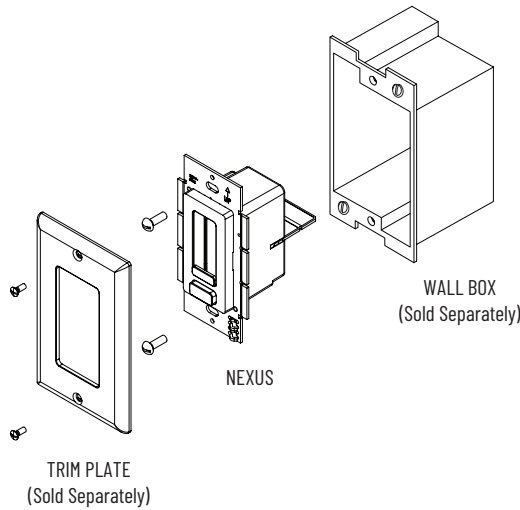

### 9. TURN POWER ON AT THE CIRCUIT BREAKER



#### SYSTEM WORKING IMPROPERLY?

Turn power OFF at circuit breaker and verify all connections. Review WIRING and TROUBLESHOOTING or call Nora Technical Support 800.686.6672

### OPERATION

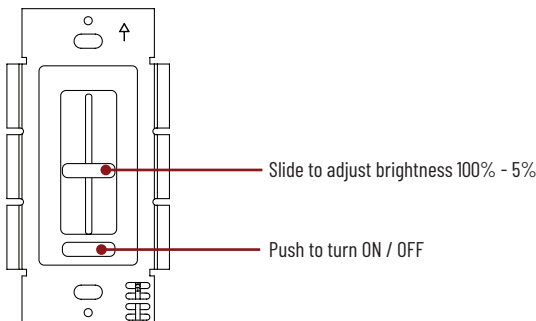

### CONSUMER ACKNOWLEDGMENT

Nora stands behind its products when they are used properly and according to our specifications. By purchasing our product, the purchaser agrees and acknowledges that lighting design, configuration and installation is a complex process, wherein seemingly minor factors or changes in layout and infield adjustments can have a significant impact on an entire system. Choosing the correct components is essential. Nora is able to work with the original purchaser to make an appropriate product selection to the extent of the limited information that the customer can provide, but it is virtually impossible for Nora to design a system that foresees every unknown factor. For this reason, this Warranty does not cover problems caused by improper design, configuration or installation issues. Any statement from a Nora employee or agent regarding a customer's bill of goods and/or purchase order is NOT an acknowledgment that the products purchased are designed and configured correctly. The purchaser agrees and acknowledges that it is the customer's responsibility to adhere strictly to all information contained in the product Specification Sheets.

### TROUBLESHOOTING

SYMPTOM	COMMON CAUSE
Fixture does not illuminate	<ul style="list-style-type: none"> <li>Incorrect wiring. Polarity of Low Voltage V+ and V- are reversed</li> <li>Circuit Breaker is OFF or tripped</li> <li>Incorrect voltage pairing of dimmer and fixture. 12V dimmer models will not power a fixture with a higher voltage rating</li> </ul>
<ul style="list-style-type: none"> <li>Different fixtures do not dim in sync</li> <li>Fixture turns off at low dim level</li> <li>Fixture strobos/flickers at low dim level</li> <li>Dimmer buzzes excessively</li> </ul>	Only install 12VDC system on the compatibility list
Fixture heats up excessively	<ul style="list-style-type: none"> <li>Incorrect voltage pairing of dimmer and fixture.</li> <li>Fixture is not compatible</li> </ul>

# Installation Instructions

NATL-SWEX60/12A

12V NEXUS Dimmer & Driver

READ PRIOR TO ATTEMPTING INSTALLATION  
 ALWAYS TURN OFF MAIN POWER BEFORE INSTALLATION  
 INSTALLATION SHOULD BE CARRIED OUT BY YOUR LOCAL ELECTRICIAN

## VOLTAGE DROP CHARTS

For best performance and lumen output, ensure proper wire gauge is installed to compensate for voltage drop of low voltage circuits.

### Example: 12V Voltage Drop & Wire Length Distance Chart

Wire Gauge	10W 0.83A	20W 1.7A	30W 2.5A	40W 3.3A	50W 2.1A	60W 4.2A
18 AWG	34 ft.	17 ft.	11 ft.	8 ft.	6 ft.	5 ft.
16 AWG	54 ft.	27 ft.	18 ft.	13 ft.	10 ft.	9 ft.
14 AWG	86 ft.	43 ft.	29 ft.	21 ft.	17 ft.	14 ft.
12 AWG	134 ft.	68 ft.	45 ft.	34 ft.	27 ft.	22 ft.
10 AWG	199 ft.	99 ft.	66 ft.	49 ft.	39 ft.	33 ft.

- Determine load size. Let's assume load is 54W.  
Round up to the nearest load.
- Determine distance from NEXUS to load.  
Let's assume the distance is 20 ft.
- It's recommended to install 12 AWG to eliminate excess voltage drop.

### 12V Voltage Drop & Wire Length Distance Chart

Wire Gauge	10W 0.83A	20W 1.7A	30W 2.5A	40W 3.3A	50W 2.1A	60W 4.2A
18 AWG	34 ft.	17 ft.	11 ft.	8 ft.	6 ft.	5 ft.
16 AWG	54 ft.	27 ft.	18 ft.	13 ft.	10 ft.	9 ft.
14 AWG	86 ft.	43 ft.	29 ft.	21 ft.	17 ft.	14 ft.
12 AWG	134 ft.	68 ft.	45 ft.	34 ft.	27 ft.	22 ft.
10 AWG	199 ft.	99 ft.	66 ft.	49 ft.	39 ft.	33 ft.

#### VOLTAGE ADJUSTMENT:

NEXUS can provide a 1V boost if the fixture is receiving noticeable light degradation.

- Pop off face plate as shown in Step 4 of INSTALLATION
- Use a small screwdriver to adjust output voltage by turning adjustment dial clockwise.

