

# Installation Instructions

NUDTW-98

Bravo FROST Tunable White LED Linear Luminaire

**READ PRIOR TO ATTEMPTING INSTALLATION**  
**ALWAYS TURN OFF MAIN POWER BEFORE INSTALLATION**  
**INSTALLATION SHOULD BE CARRIED OUT BY YOUR LOCAL ELECTRICIAN**

**⚠ FIRE/ELECTRICAL HAZARD: INSTALL ACCORDING TO NATIONAL ELECTRIC CODE AND ANY APPLICABLE MUNICIPAL CODE REQUIREMENTS:** This equipment is intended to be installed only by qualified personnel. The installation must be made in accordance with the current edition to the National Electric Code and all applicable state and local building codes. The final installation must be approved by the appropriate qualified electrical/building inspector(s). Improper installation may result in a fire or electrical hazard. Be sure the electrical power to the circuit has been disconnected before installing this electrical system.

**⚠ RISQUE D'INCENDIE / D'ÉLECTRICITÉ: INSTALLER SELON LE CODE ÉLECTRIQUE NATIONAL ET TOUTES LES EXIGENCES RELATIVES AU CODE MUNICIPAL APPLICABLE:** Cet équipement est destiné à être installé uniquement par du personnel qualifié. L'installation doit être faite conformément à l'édition actuelle du Code national de l'électricité et de tous les codes de construction locaux et nationaux applicables. L'installation finale doit être approuvée par un ou plusieurs inspecteurs qualifiés en électricité / bâtiment. Une installation incorrecte peut entraîner un incendie ou un risque électrique. Assurez-vous que l'alimentation électrique du circuit a été déconnectée avant d'installer ce système électrique.

Item No.	Description	Rating
NUDTW-9812	12" Bravo FROST TW	120V, 10W
NUDTW-9816	16" Bravo FROST TW	120V, 13W
NUDTW-9824	24" Bravo FROST TW	120V, 20W
NUDTW-9832	32" Bravo FROST TW	120V, 26W

**⚠ CAUTION:**

- Always turn off power prior to installation or replacement
- Risk of electric shock. Do not allow any connection pin to touch any electrical conductors
- Do not press directly on the top cover, as it may cause damage
- For indoor use only. Do not use the product in a potentially combustive environment or outdoors
- Maximum wattage per run is 300W
- Can be used with portable cabinet light accessory providing 10' total cord length

**JUNCTION BOX (NUA-902W) INSTALLATION:**

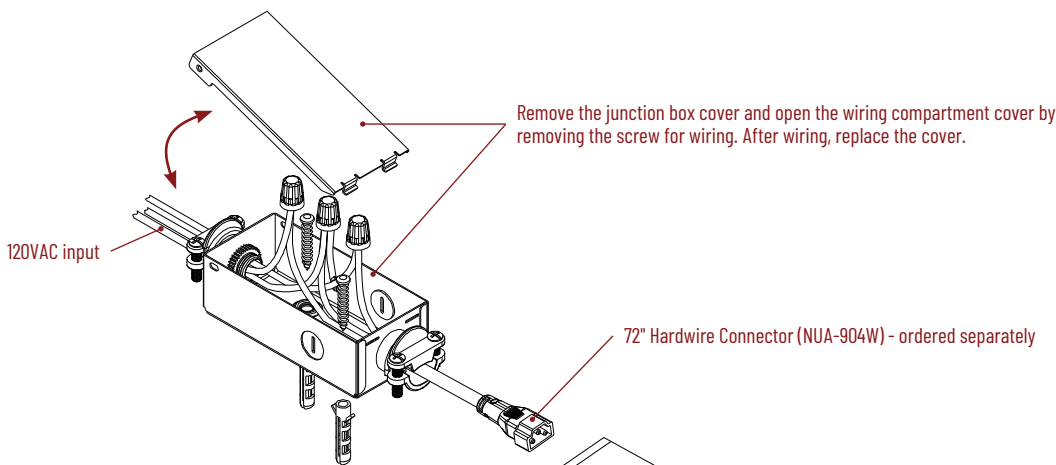

**MOUNTING BRACKET INSTALLATION:**

Secure supplied mounting brackets to surface.

**NOTE:** Adjustable mounting brackets only pivot in one direction.

Decide which direction is required if planning on adjusting and mount accordingly. To adjust pivot angle, follow steps A and B.

