

# Installation Instructions

\*\*\*URGENT: READ PRIOR TO ATTEMPTING INSTALLATION\*\*\*

## NSW-67 SERIES MIA DIE-CAST LED MINI STEP LIGHTS

ALWAYS TURN OFF MAIN POWER BEFORE INSTALLATION

### **WARNING: Fire/Electrical Hazard**

This equipment is intended to be installed only by qualified personnel. The installation must be made in accordance with the current edition to the National Electric Code and all applicable state and local building codes. The final installation must be approved by the appropriate qualified electrical/building inspector(s). Improper installation may result in a fire or electrical hazard. Be sure the electrical power to the circuit has been disconnected before installing this electrical system.

### INSTRUCTIONS:

- 1) Fix Trim plate ② to the Face plate holder ①;
- 2) Fix the Trim plate ① to the LED Light engine housing ③, using the Supplied screws ④ To secure LED Light engine housing ③; From the back as shown on drawing with supplied screws.
- 3) Now, you should have Trim plate+Face plate+LED light engine all in one piece ⑤;

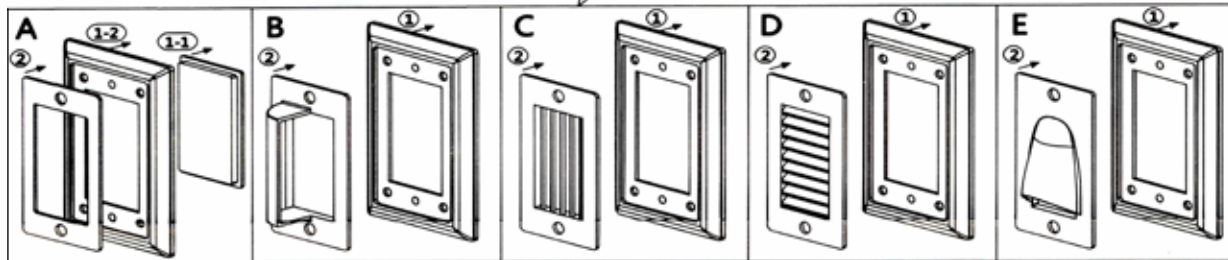
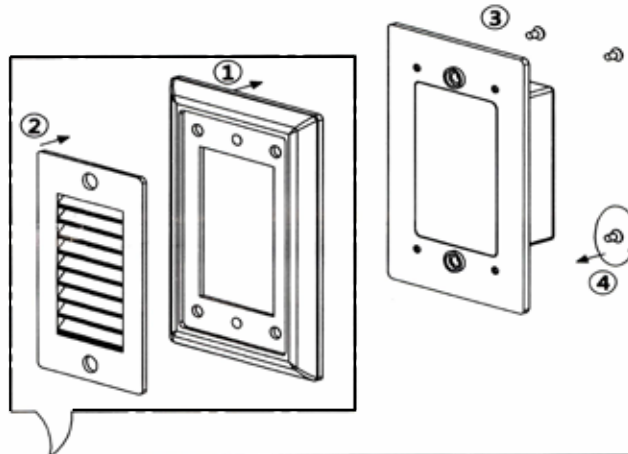

- 4) Connect the LED Step light fixture's 7" 18AWG leads (Black is hot, White is neutral/common) to the electrical outlet box ⑦ (Not supplied) wire leads using the wire connectors provided in your screws pack as per the diagram. Make sure the "black lead" from the fixture goes to the "black supply lead", and the "white lead" from the fixture goes to the "white supply lead";
- 5) To fasten LED Step Light fixture ⑤ onto the junction box ⑦, using the junction box screws ⑧ To lock down and secure.

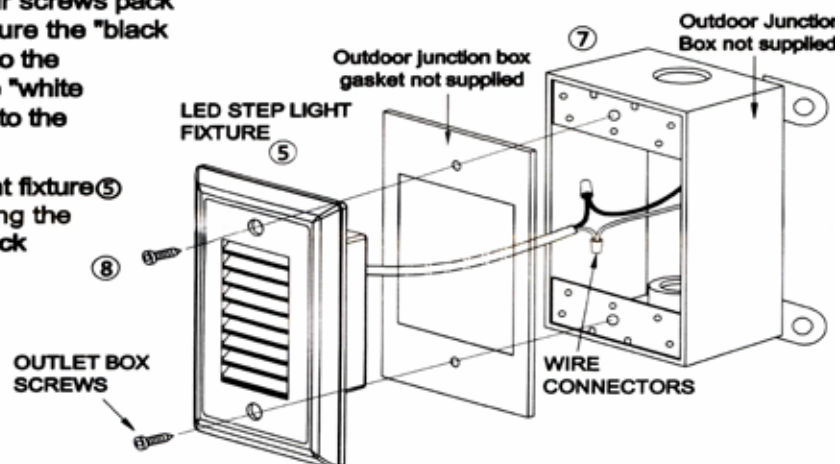

**CAUTION: ALL ELECTRICAL CONNECTIONS MUST BE IN ACCORDANCE WITH LOCAL CODES, ORDINANCES AND THE NEC CODE. IF YOU ARE UNFAMILIAR WITH METHODS OF INSTALLING ELECTRIC WIRING, CONSULT A QUALIFIED LICENSED ELECTRICIAN.**