

Installation Instructions

NYLD2-6C

6" Cable Mounted Cobalt Cylinder

READ PRIOR TO ATTEMPTING INSTALLATION
ALWAYS TURN OFF MAIN POWER BEFORE INSTALLATION
INSTALLATION SHOULD BE CARRIED OUT BY YOUR LOCAL ELECTRICIAN

⚠ FIRE/ELECTRICAL HAZARD: INSTALL ACCORDING TO NATIONAL ELECTRIC CODE AND ANY APPLICABLE MUNICIPAL CODE REQUIREMENTS. - This equipment is intended to be installed only by qualified personnel. The installation must be made in accordance with the current edition to the National Electric Code and all applicable state and local building codes. The final installation must be approved by the appropriate qualified electrical/building inspector(s). Improper installation may result in a fire or electrical hazard. Be sure the electrical power to the circuit has been disconnected before installing this electrical system.

⚠ RISQUE D'INCENDIE / D'ÉLECTRICITÉ: INSTALLER SELON LE CODE ÉLECTRIQUE NATIONAL ET TOUTES LES EXIGENCES RELATIVES AU CODE MUNICIPAL APPLICABLE. - Cet équipement est destiné à être installé uniquement par du personnel qualifié. L'installation doit être faite conformément à l'édition actuelle du Code national de l'électricité et de tous les codes de construction locaux et nationaux applicables. L'installation finale doit être approuvée par un ou plusieurs inspecteurs qualifiés en électricité / bâtiment. Une installation incorrecte peut entraîner un incendie ou un risque électrique. Assurez-vous que l'alimentation électrique du circuit a été déconnectée avant d'installer ce système électrique.

CABLE MOUNT INSTALLATION

1. Ensure electrical power is off.
2. Loosen strain relief on power cord to adjust to desired length. (Figure 1)
3. Adjust aircraft cable length by depressing cable gripper. (Figure 1)
4. Run power cord through junction box plate. Connect supply wires to power cord, refer to "ELECTRICAL CONNECTIONS" below to make the electrical connections.
5. Attach the junction box plate to junction box with screws (not included). (Figure 2)
6. Place canopy over junction plate and secure with screws (included). (Figure 3)
7. Connect ideal connector from LED driver to Cobalt reflector. (Figure 4)
8. Push reflector into cylinder until flush.

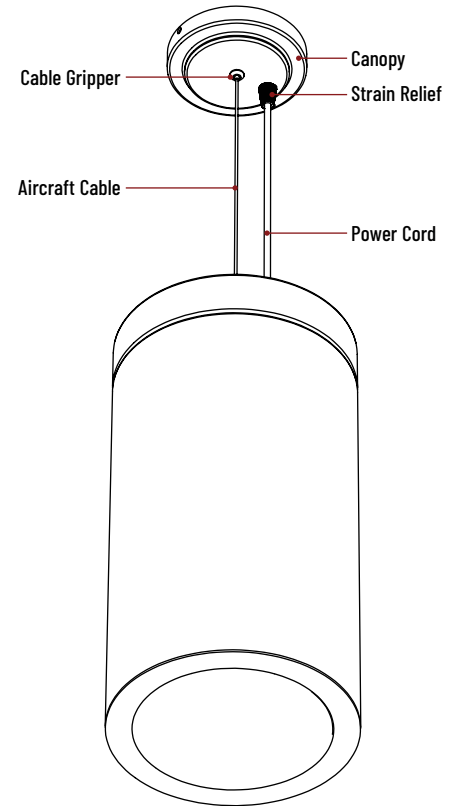
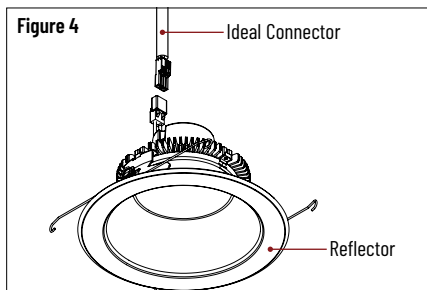
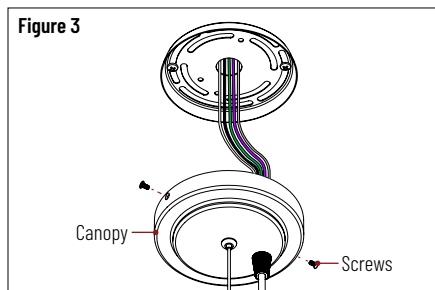
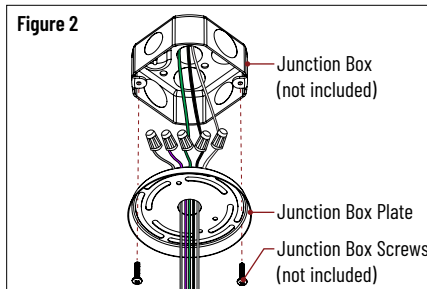
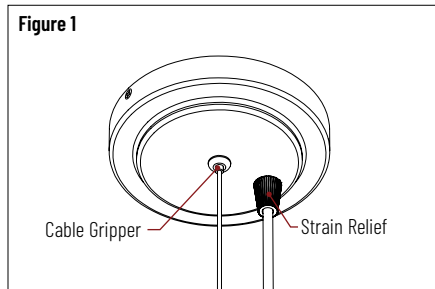

ELECTRICAL CONNECTIONS

- Connect wires accordingly:
- Black Wire = Live (Hot)
 - White Wire = Neutral
 - Green or Copper Wire = Grounding Junction Box Wire
- 0-10V Wiring:
- Purple = Dim (+)
 - Pink or Grey = Dim (-)

NOTE ON GROUNDING: Many structures carry grounding via steel conduit. If this is the case, if there is no grounding wire, simply leave green wire on fixture unattached. Fixture will be grounded through attachment of conduit to junction box. However, if Romex or PVC conduit is used, ground wire will always be present, and must be connected to green wire on fixture junction box to avoid electrical shock hazard.

120/277V CONNECTION:

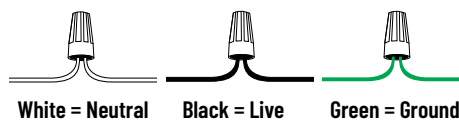

0-10V DIMMING CONNECTION:

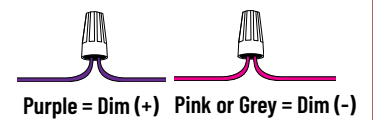

0-10V DIMMING CONNECTION:

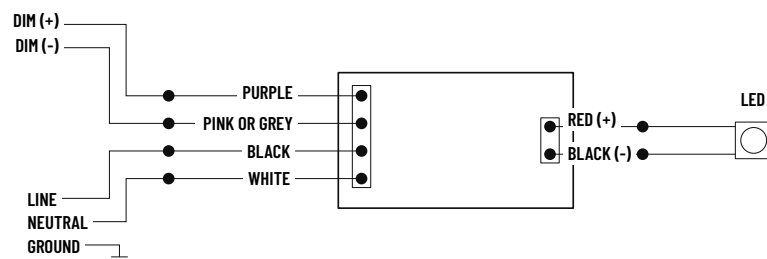

* cap off 0-10V dimming wires if not used *

Installation Instructions

NYLD2-6C

6" Cable Mounted Cobalt Cylinder

READ PRIOR TO ATTEMPTING INSTALLATION
 ALWAYS TURN OFF MAIN POWER BEFORE INSTALLATION
 INSTALLATION SHOULD BE CARRIED OUT BY YOUR LOCAL ELECTRICIAN

EMERGENCY CONNECTION (NEPK-07LEDUNV)

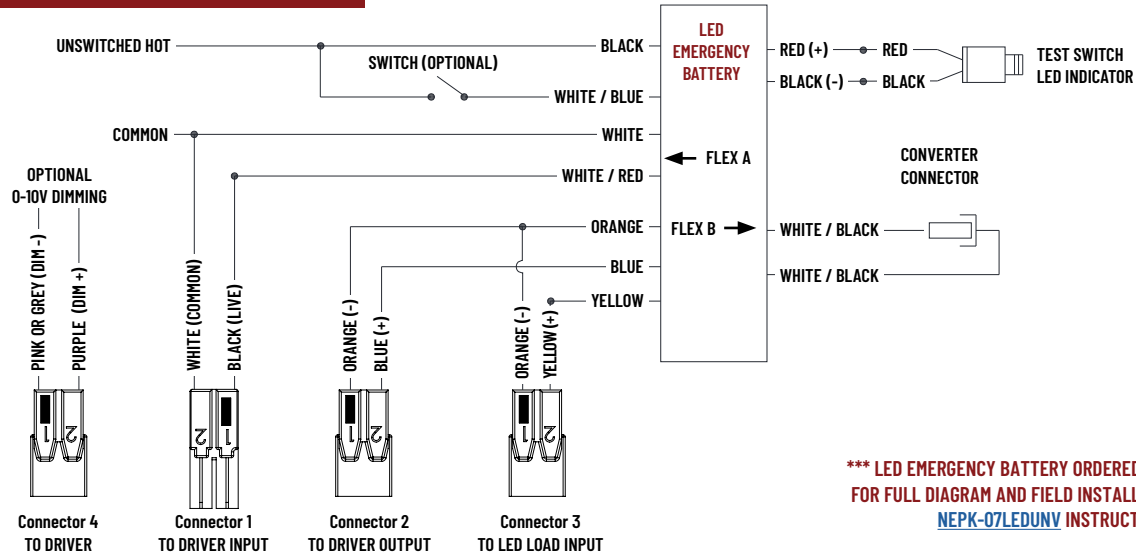

*** LED EMERGENCY BATTERY ORDERED SEPARATELY***
 FOR FULL DIAGRAM AND FIELD INSTALLATION, REFER TO
[NEPK-07LEDUNV INSTRUCTIONS](#)

CONNECTOR 1

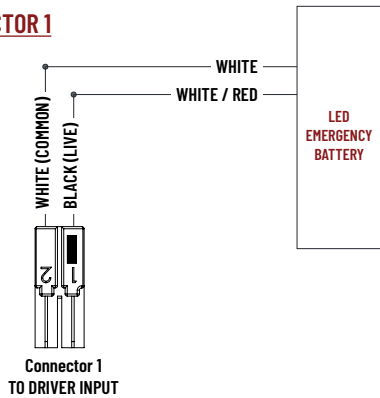

CONNECTOR 2

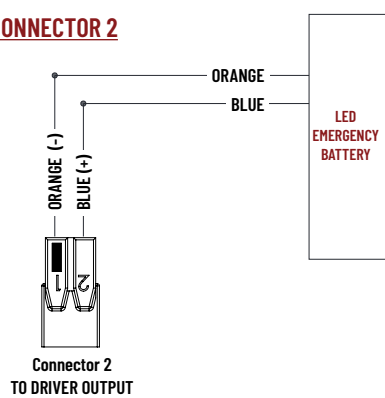

CONNECTOR 3

