

# INSTALLATION INSTRUCTIONS

## IMPORTANT SAFEGUARDS

### READ AND FOLLOW ALL SAFETY INSTRUCTIONS

1. Review the diagrams thoroughly before beginning.
2. All electrical connections must be in accordance with local codes, ordinances, and the National Electric code.
3. Disconnect power at fuse or circuit breaker before installing or servicing.
4. Unit suitable for outdoor use.
5. Do not mount in hazardous locations, or near gas or electric heaters.
6. Do not let power cords touch hot surface.
7. Equipment should be mounted in locations and at heights where it will not be subjected to tampering by unauthorized personnel.
8. The use of accessory equipment not recommend by the manufacturer may cause an unsafe condition.
9. Do not use this equipment for other than intended use.
10. All servicing should be performed by a qualified personnel only.
11. Allow battery to charge for 24 hours before full duration test.

## SAVE THESE INSTRUCTIONS

### MAINTENANCE

Always disconnect power at fuse or circuit breaker before installing or servicing, servicing should be performed only by qualified personnel. BATTERY should be tested periodically and replaced when it no longer meet the required duration of 30 second or 90 minutes. Battery have to recharge if product keep in stock over 9 months, detail manual refer "BATTERY STOCK AND RECHARGE GUIDELINE".

### OPERATION

1. Apply AC power to the unit, LED indicator light turn on.
2. Push the test switch, the LED indicator turns off and the LED board stays on .
3. Release the test switch,LED indicator will turn on.

### TROUBLE SHOOTING GUIDE

If LED board or LED indicator does not illuminate, check the following:

1. Check AC supply - verify that unit has 24 hours AC supply.
2. Battery is not connected.
3. Battery voltage too low- Permit unit to charge for 24 hours then re-test.
4. If above trouble shooting hints do not solve the problem, contact us for assistance.

### ROUTINE TESTING

National Electric Code (NEC) and NFPA life safety code regulations require that routine tests need to be performed as below: Once every month, perform 30 seconds duration test, push in and hold the test switch to perform this test.

Once every 12 months, perform full 90 minutes test, disconnect AC power supply and transfer to emergency mode, the unit should stay on 90 minutes minimum.

### MAX. MOUNTING HEIGHT:

WCU.....22 FT

WCU-RC.....18 FT

#### Open front cover

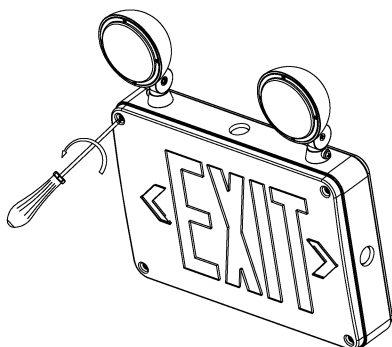
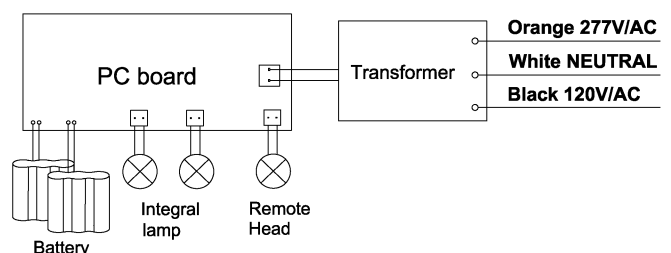


Fig 1

#### Wiring diagram



Connect the white wire to neutral.  
If using 120V, connect the black wire to the hot lead.  
If using 277V, connect the orange wire to the hot lead.  
Cap the unused lead.

## Wall Mounting (see Fig 2)

1. Open front cover by screwdriver (see Fig 1).
2. Knock out center and appropriate mounting screw holes on the back plate, paste gasket on back of back plate
3. Feed building power supply wires through the center hole, fix back plate to waterproof type junction box by screws.
4. Make correct electrical connections inside of fixture according wiring diagram.
5. Push excess wire into junction box.
6. Attach battery connector to PC board.
7. Snap chevron to EXIT panel if required, restore front panel on unit.

## Side Mounting (see Fig 3)

1. Attach crossbar to J-box set the crossbar so that the longer blade is touching the waterproof type junction box.
2. Open front cover by screwdriver.
3. If double face is desired, replace back plate with additional face plate provided.
4. Knock out the mounting hole on the top or side of the unit, assemble the canopy on the unit (see Fig 5).
5. Route the proper wires through mounting hole out of housing .
6. Make electrical connections inside the J-box as wiring diagram.
7. Fasten crossbar on J-box by screws provided.
8. Paste gasket on canopy, then fasten canopy to crossbar and against to the wall.
8. Snap chevron to EXIT panel if required.
9. Attach battery connector to PC board, restore front panel on unit.

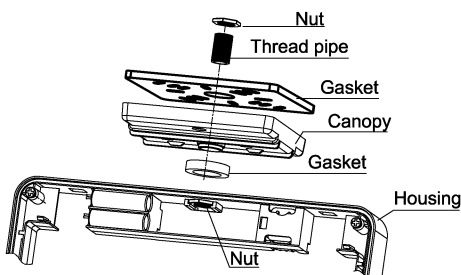
## Ceiling suspend mount (see Fig 4)

1. Preinstall mounting pipe and fix junction box on the mounting pipe (use local standard accessories).
2. Rest install process refer to side mounting phase.  
The difference is wiring knock out hole is on the top of housing.

## Connecting Remote heads (see Fig 4)

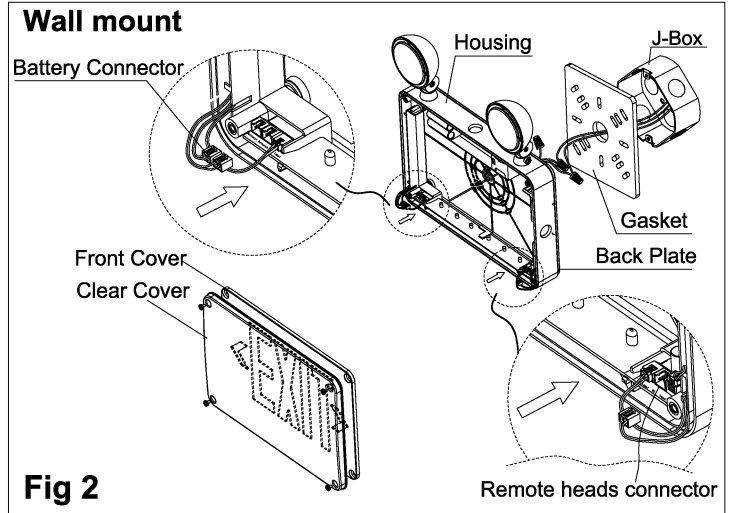
If fixture has remote capability option, Max. remote capability is 3.6VDC1.5W. Connect remote heads extension wire to remote wire, yellow is positive(+), purple is negative(-), connect wires using wire nuts.  
Notice: for constant output remote head, remote capability 0.75W max

### Canopy assembly

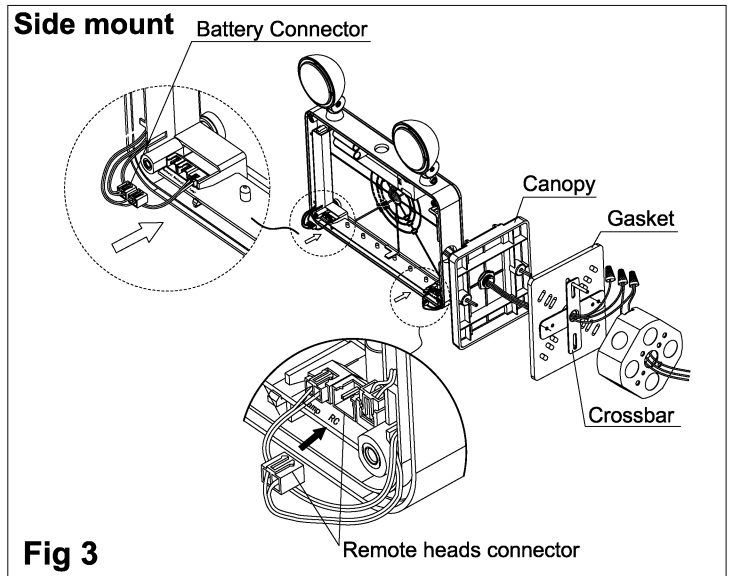


**Fig 5**

Use provided thread pipe and 2 nut fix canopy on unit, put gasket between unit and canopy.



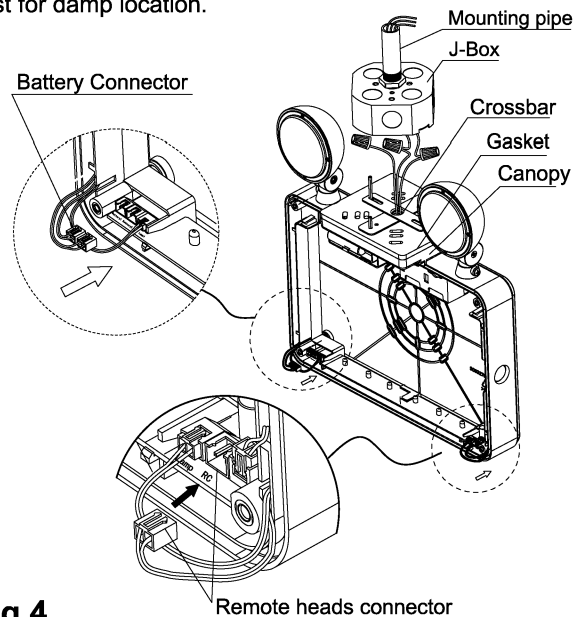
**Fig 2**



**Fig 3**

### Ceiling suspend mount

This installation method will invalid waterproof function. Just for damp location.



**Fig 4**