

# Installation Instructions

## NLWPSW-2L334W

### 2' Wraparound with Selectable Lumens & CCT

**READ PRIOR TO ATTEMPTING INSTALLATION**  
**ALWAYS TURN OFF MAIN POWER BEFORE INSTALLATION**  
**INSTALLATION SHOULD BE CARRIED OUT BY YOUR LOCAL ELECTRICIAN**

- ⚠ WARNING** - Risk of fire or Electric shock.
- To reduce the risk of fire, electric shock or injury to persons; read and follow all warning and installation instructions before installing.
  - All installation should be performed by a qualified electrician.
  - To avoid electric shock, ensure power is turned off before installation.
  - All wiring must be installed in accordance with all Electrical Codes.
  - To prevent product malfunction and/or electrical shock, this product must be properly grounded.
  - Suitable for non-insulated frame. **DO NOT** cover fixture with insulation liner or similar material.
  - **DO NOT** install fixture on unstable or easily breakable surface.
  - **DO NOT** exert force on the surface of the fixture.

- ⚠ AVERTISSEMENT** - Risque d'incendie ou de décharge électrique.
- Pour réduire le risque d'incendie, de décharge électrique ou de blessure, lire et suivre les avertissements et les instructions d'installation avant d'installer le produit.
  - L'installation doit être effectuée par un électricien qualifié.
  - Pour éviter toute décharge électrique, s'assurer que le courant est coupé avant de procéder à l'installation. Tout le câblage doit être installé conformément aux codes de l'électricité.
  - Pour éviter le mauvais fonctionnement du produit ou une décharge électrique, ce produit doit être correctement mis à la terre.
  - Convient à une surface et à un cadre non isolés. **NE PAS** recouvrir le luminaire d'une doublure isolante ou autre matière similaire.
  - **NE PAS** installer le luminaire sur une surface instable ou facilement cassable.
  - **NE PAS** exercer de force sur la surface du luminaire.



#### COMPATIBLE JUNCTION BOXES

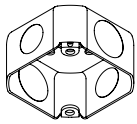

3" Octagonal

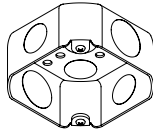

4" Octagonal

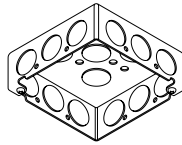

4" Square

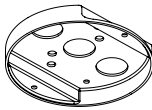

4" Pancake

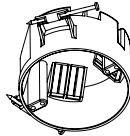

4" Plastic Round



#### PACKAGING CONTENTS

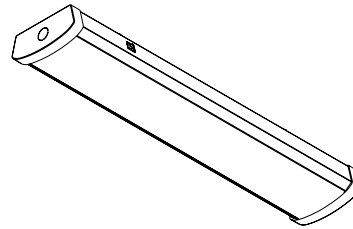

(1) Luminaire



(4) Drywall Anchors



(5) Wire Nuts



(4) Drywall Screws



(1) Suction Cup



(2) Junction Box Screws

#### EXPLODED VIEW

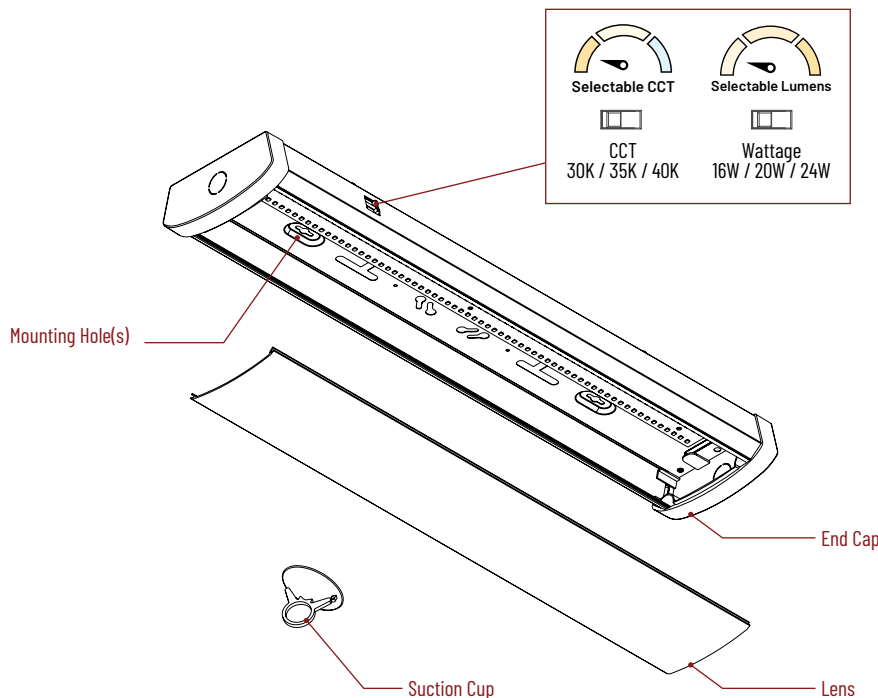

# Installation Instructions

NLWPSW-2L334W

2' Wraparound with Selectable Lumens & CCT

READ PRIOR TO ATTEMPTING INSTALLATION  
ALWAYS TURN OFF MAIN POWER BEFORE INSTALLATION  
INSTALLATION SHOULD BE CARRIED OUT BY YOUR LOCAL ELECTRICIAN

## SURFACE MOUNTED LUMINAIRE INSTALLATION

**1** Remove lens with suction cup starting from one side.

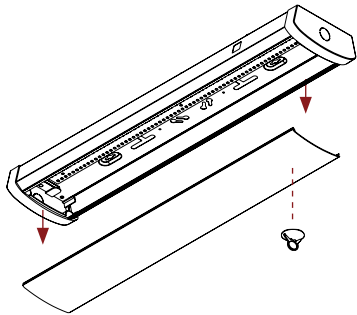

**2** Punch out the knockout(s) that correspond to the desired junction box type.

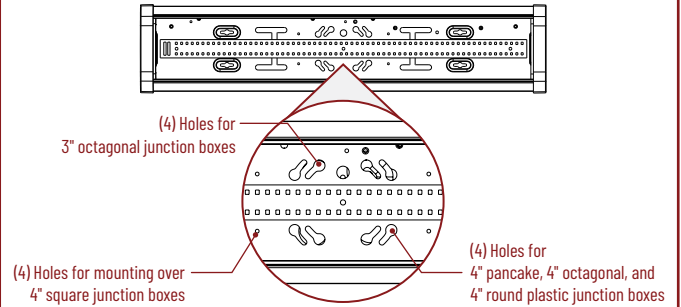

**3** Connect power feed wires and fasten luminaire to ceiling with hardware (included). If using 4" rectangular junction boxes, use screws (not provided) to secure the center of the fixture to the ceiling through the holes shown.

Neutral	White
Ground	Green
Line	Black
Dim (+)	Purple
Dim (-)	Gray (or Pink)

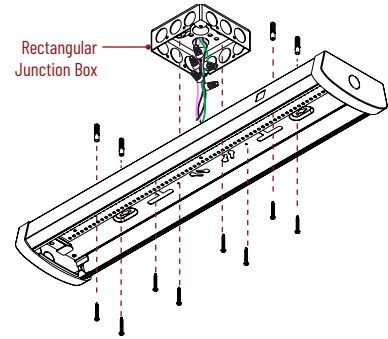
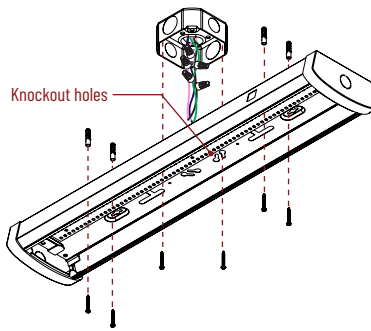

**4** Replace the lens by inserting into one side and pressing towards the other direction until lens is fully seated.

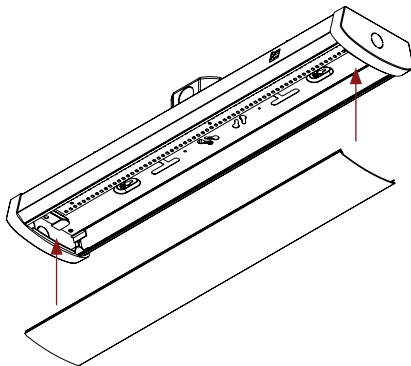

**5** Installation Complete.  
Turn power on to confirm fixture is functioning properly.



# Installation Instructions

NLWPSW-2L334W

2' Wraparound with Selectable Lumens & CCT

READ PRIOR TO ATTEMPTING INSTALLATION  
ALWAYS TURN OFF MAIN POWER BEFORE INSTALLATION  
INSTALLATION SHOULD BE CARRIED OUT BY YOUR LOCAL ELECTRICIAN

## CONTINUOUS RUN / DAISY CHAIN INSTALLATION

**1** Remove lens with suction cup starting from one side.

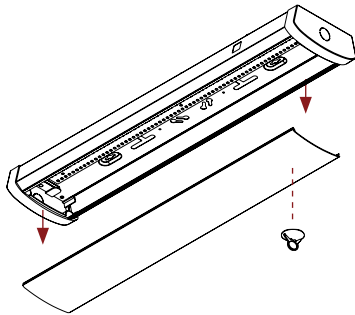

**2** Punch out the knockout(s) that correspond to the desired junction box type.

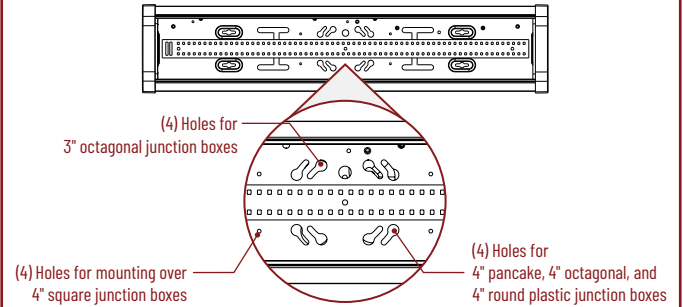

**3** Connect power feed wires and fasten luminaire to ceiling with hardware (included). If using 4" rectangular junction boxes, use screws (not provided) to secure the center of the fixture to the ceiling through the holes shown.

Neutral	White
Ground	Green
Line	Black
Dim (+)	Purple
Dim (-)	Gray (or Pink)

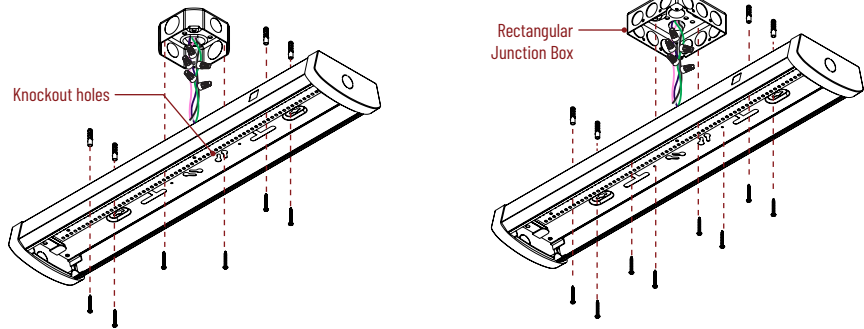

**4** Remove lens from second fixture.

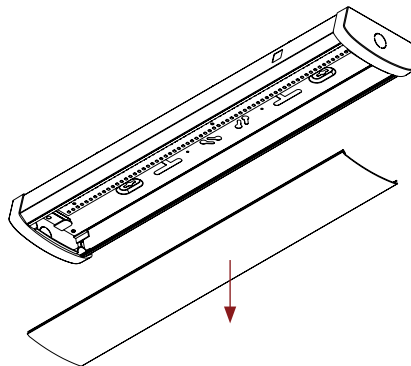

# Installation Instructions

NLWPSW-2L334W

2' Wraparound with Selectable Lumens & CCT

READ PRIOR TO ATTEMPTING INSTALLATION  
ALWAYS TURN OFF MAIN POWER BEFORE INSTALLATION  
INSTALLATION SHOULD BE CARRIED OUT BY YOUR LOCAL ELECTRICIAN

## CONTINUOUS RUN / DAISY CHAIN INSTALLATION (CONTINUED)

**5** Remove corresponding end cap knockouts, and fasten second fixture into the ceiling.

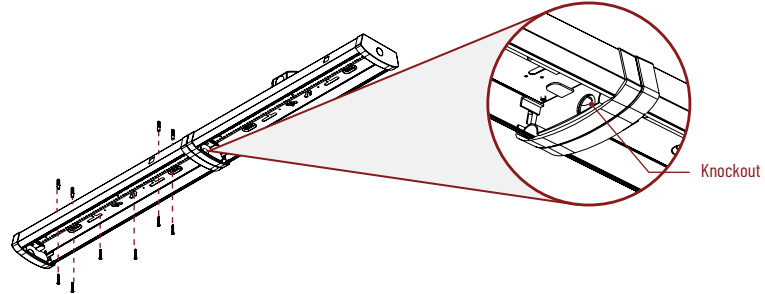

**6** Connect power and dimming wires from second fixture to wires of first fixture.

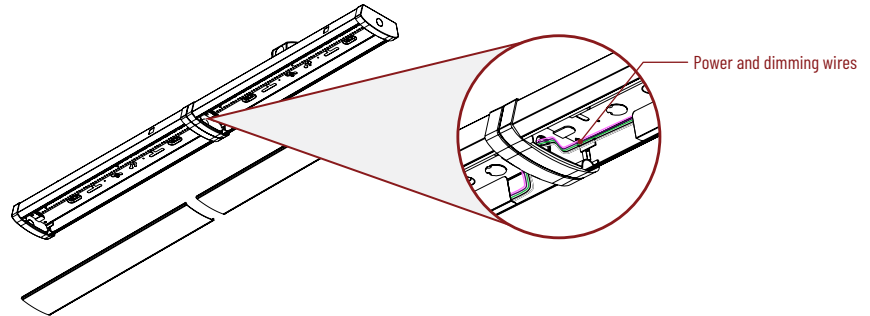

**7** Reinstall lenses on both fixtures. Installation complete!

